

## Specifications

<b>Dimensions Solid Base</b>	6.38 (L) x 3.50 (W) x 3.00 (D) inches (16.21 x 8.89 x 7.62 cm)
<b>Dimensions Ring Base</b>	6.38 (L) x 3.50 (W) x 3.25 (D) inches (16.21 x 8.89 x 8.26 cm)

## Assembly Instructions

The protective case for the HOBO® MX CO<sub>2</sub> logger (MX1102) includes two mounting base types:

- The ring base can be used if the logger to be protected is already attached to the wall.
- The solid base can be used in place of the ring base if another mounting method is desired.

Use the included screws to attach the case to the wall and use the mounting hardware included with the logger to attach it to the case.

To secure the case cover to the base, slide the teeth on the base into the vent holes on the case cover.

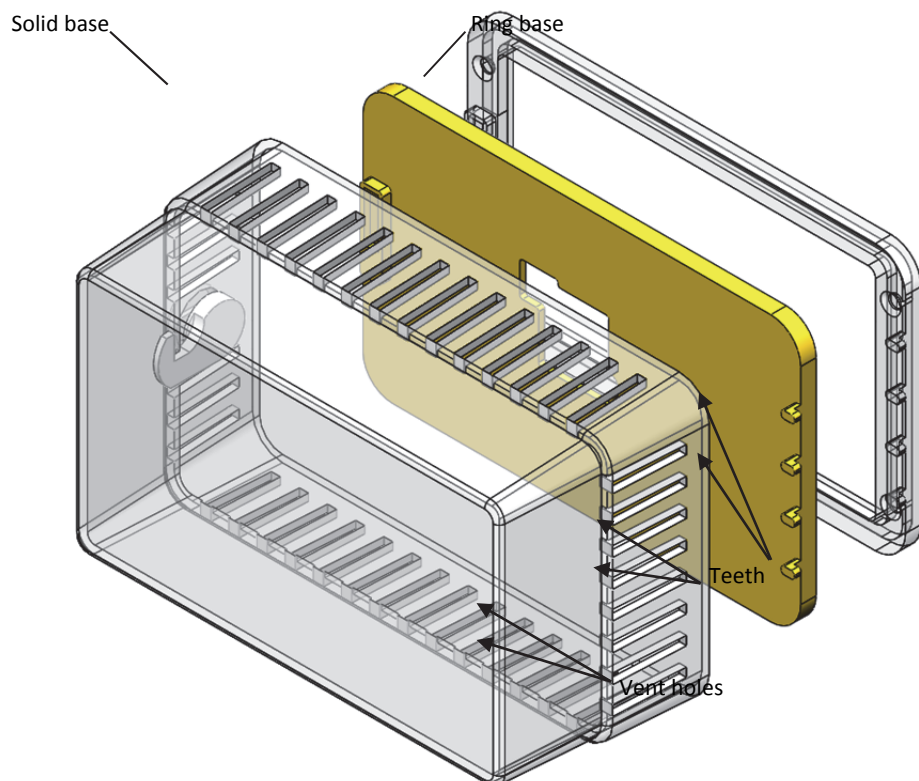

## Features

- Clear case cover
- Mounting screws
- Solid mounting base
- Ring mounting base
- Built-in lock with one key